

# Total Heat Exchangers

## Residential Series

Particularly suitable for modern homes with high insulation afforded by double glazing and cavity insulation, which require ventilation to remove stale air without major heat loss.

- > Effective fresh air ventilation
- > Efficient recovery of heating/cooling energy
- > Good sound attenuation
- > Reduces heating costs

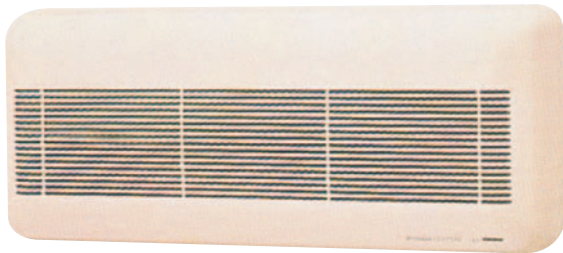

[Technical Information >>](#)

LOSSNAY		
MODEL REFERENCE		RESIDENTIAL WALL- MOUNTED VL 100U
ELECTRICAL POWER SUPPLY		220 - 240V, 50Hz
PHASE		Single
POWER CONSUMPTION (W)	Low	23
	High	26
AIRFLOW (m <sup>3</sup> /h)	Low	65
	High	105
NOISE (dBA)	Low	29.5
	High	39
EFFICIENCY (%)	Low	77
	High	70
WEIGHT (kg)		6.5
DIMENSIONS (mm)	Width	620
	Depth	168
	Height	265
DUCT SIZE (mm)		2xØ75
FUZE RATING (BS88) – HRC (A)		6
MAINS CABLE No. Cores		3

VL 100U

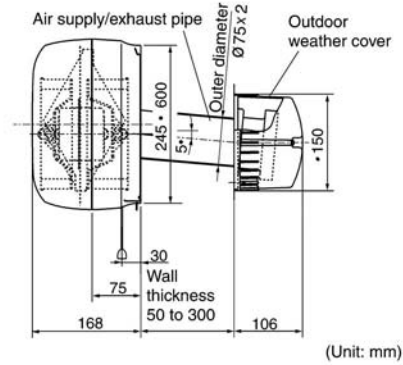
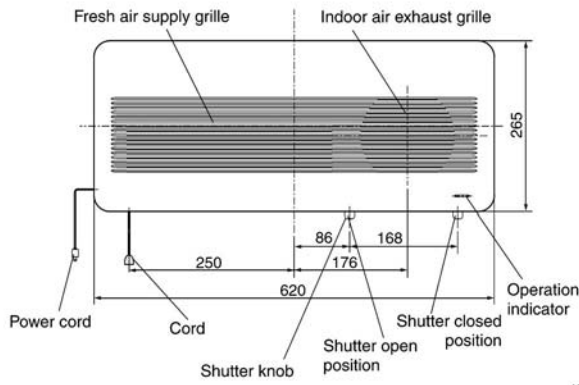
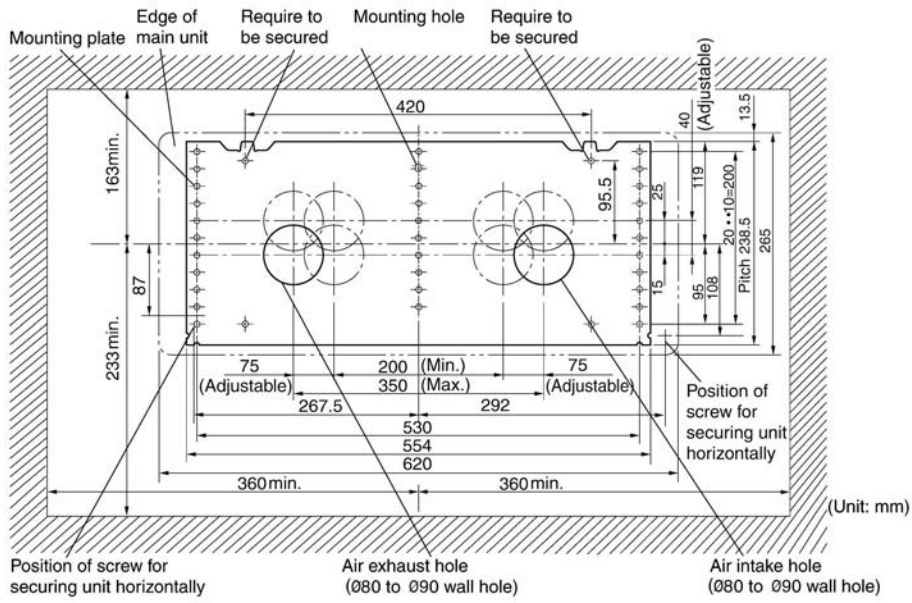

If the wall is thicker than 300 mm, use the extension pipes and the pipe extension joints (separately sold parts).

**This pdf has been downloaded from the website of :**

“Supplying and installing the latest in air conditioning technology”

**° Celsius**  
**air conditioning**

Celsius Air Conditioning Ltd, 1 Well Street, Heywood, Greater Manchester OL10 1NT

 01706 367 500  07000 CELSIUS  01706 367 355  sales@celsiusair.co.uk  www.celsiusair.co.uk

**www.celsiusair.co.uk**